

Scheda tecnica UW3 T TIZ 6,5 X 35



Tabella tecnica autoperforante

<p>Trazione</p>  <p>14500 N</p>	 <p>Spessore [mm]</p>	<p>Sfilamento S235JRC</p> 	<p>Sfilamento legno abete</p> 
<p>Taglio</p>  <p>7800 N</p>		<p>0.6 1 2</p>	<p>1100 N 2010 N 5550 N</p>

N=Newton 1N=kgf 0.1019716

I valori indicati rappresentano il valore caratteristico derivanti dalle diverse sessioni di prove.

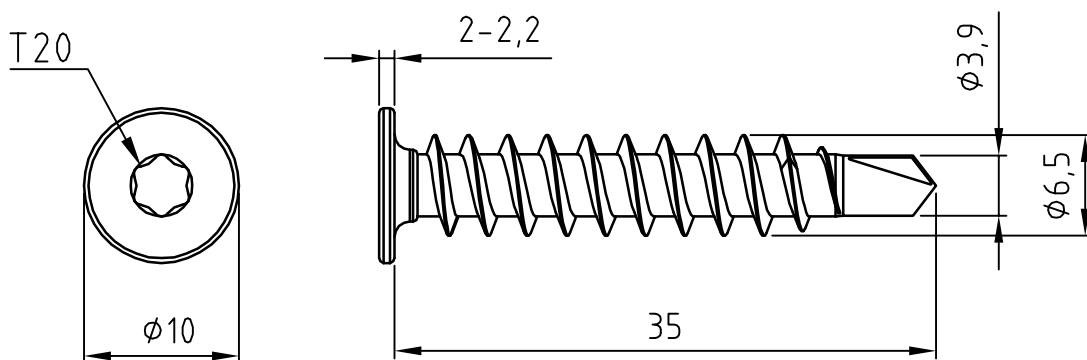
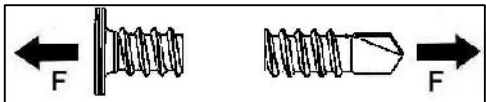
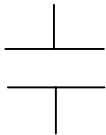
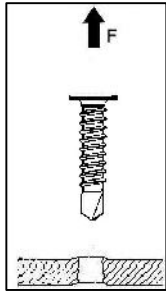
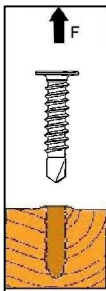
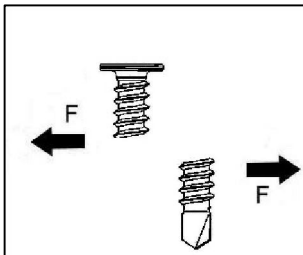
MATERIALE: Acciaio al carbonio C18

TRATTAMENTO: Carbonitrurazione

RIVESTIMENTO: Lanthane 175

SCALA: 2:1

FIRMA: Uff. Tecnico

DATA: 30/07/2014



DESCRIZIONE: UW3 T TIZ 6,5 X 35

Ufficio Tecnico
Via dell'Industria,12
20032 Cormano - Mi
TEL. 02/6192097

DESCRIZIONE DETTAGLIATA:

Vite autoperforante punta ridotta per ferro e legno testa piatta.