

Scheda tecnica UND6 6.3xL





Tabella Tecnica Autoperforanti

Trazione  19.000 N		Sfilamento ferro
Taglio  12.000 N		
N=Newton 1N=kgf 0.1019716	Spessore [mm]	2 4.081 N 3 6.500 N 4 9.000 N 5 12.600 N 6 15.500 N

MATERIALE: Acciaio al carbonio C21

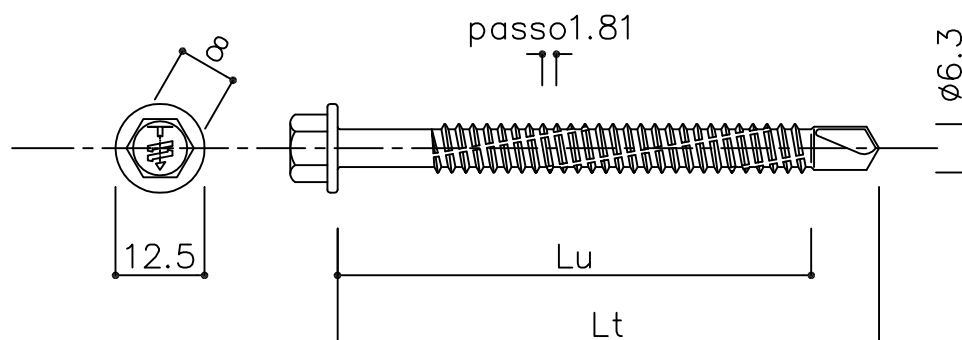
TRATTAMENTO: Carbonitrurazione

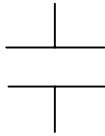
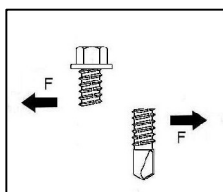
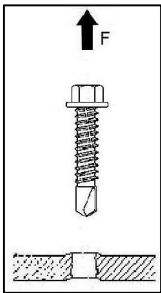
RIVESTIMENTO: Lanthane 175

SCALA: 1:1

FIRMA: F. Paxia

DATA: 07/06/2011



UFFICIO TECNICO
Via dell'Industria,12
20032 Cormano (Mi)
TEL. 02/6192097

DESCRIZIONE: UND6 6,3 X L

DESCRIZIONE DETTAGLIATA:

Vite autoperforante Lanthane.