

Scheda tecnica UL2X 4,8 X 19





Tabella Tecnica vite bi-metal per cuciture

<p>Trazione</p>  <p>7100 N</p>	<p>Sfilamento ferro</p>	<p>Spessore [mm]</p>	<p>Valore di estrazione (N)</p>
<p>Taglio</p>  <p>6200 N</p>		<p>2 X 0,6</p>	<p>1075 N</p>
<p>N=Newton 1N=kgf 0.1019716</p>			

MATERIALE: Acciaio Inox 304L
 MATERIALE PUNTA: Acciaio carbonio
 RIVESTIMENTO: Lubrificante di zincatura

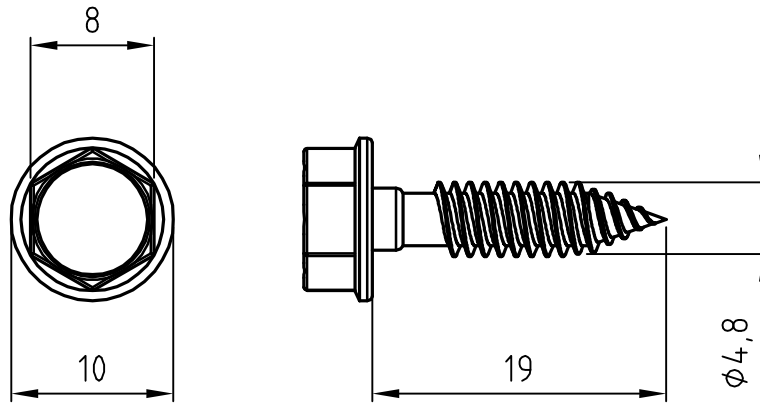
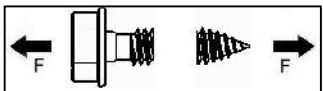
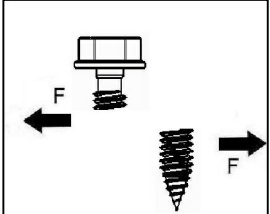
SCALA: 2:1
 FIRMA: Uff. Tecnico
 DATA: 14/02/2014



UFFICIO TECNICO
 Via dell'Industria,12
 20032 Cormano - Mi
 TEL. 02/6192097

DESCRIZIONE: **UL2X 4,8 X 19**

DESCRIZIONE DETTAGLIATA :

Vite autoperforante bimetallica per cuciture.