

Scheda tecnica UL2P 4,8 X 19





Tabella Tecnica vite zincata per cuciture

| | | | |
|--|---|--------------------------|-------------------------------------|
| <p>Trazione</p>  <p>10000 N</p> | <p>Sfilamento ferro</p> | <p>Spessore [mm]</p> | <p>Valore di estrazione (N)</p> |
| <p>Taglio</p>  <p>6300 N</p> |  | <p>2 X 0,6</p> | <p>1075 N</p> |
| <p>N=Newton 1N=kgf 0.1019716</p> | | | |

MATERIALE: Acciaio Carbonio
 Trattamento: Carbonitrurazione
 RIVESTIMENTO: Lubrificante di zincatura

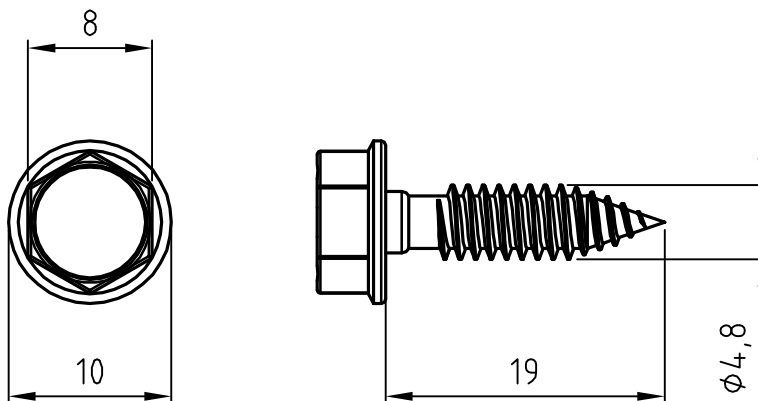
SCALA: 2:1
 FIRMA: Uff. Tecnico
 DATA: 14/02/2014

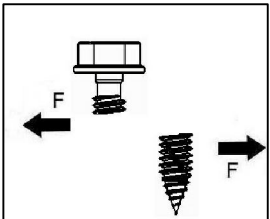
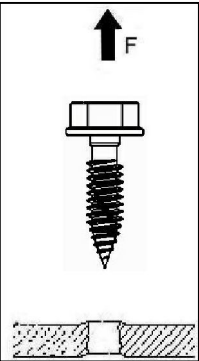

UFFICIO TECNICO
 Via dell'Industria,12
 20032 Cormano - Mi
 TEL. 02/6192097

DESCRIZIONE: **UL2P 4,8 X 19**

DESCRIZIONE DETTAGLIATA :

Vite autoperforante zincata per cuciture.