

Scheda tecnica UDCT 6.3xL







Tabella Tecnica Autoformante per ferro

Trazione		19.000 N	 Spessore [mm]	 Preforo [mm]	Sfilamento ferro	
Taglio		12.000 N				
N=Newton	1N=kgf 0.1019716	3	5	6.580 N		
		4	5.35	9.080 N		
		5	5.60	12.600 N		
		6	5.80	15.500 N		

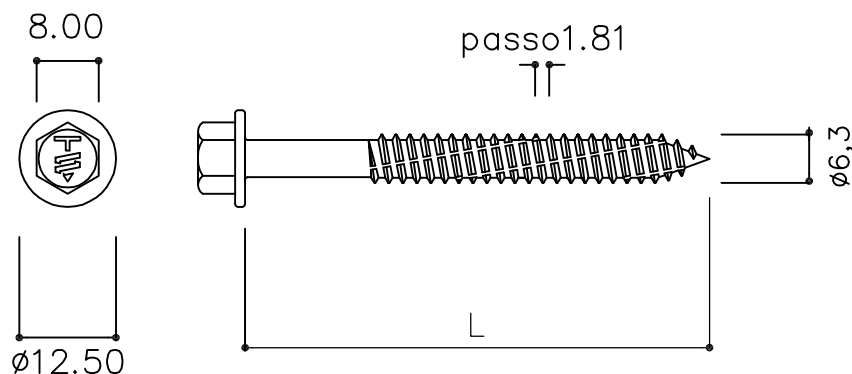
Si consiglia l'utilizzo di avvitatori dotati di limitatori di profondità e velocità sotto carico di 1000/1500 giri

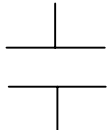
MATERIALE: Acciaio al carbonio C18

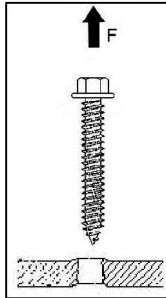
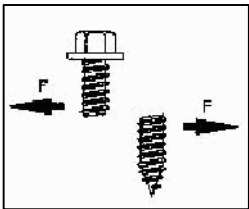
SCALA: 1:1

TRATTAMENTO: Carbonitrurazione

FIRMA: F. Paxia

RIVESTIMENTO: Lanthane 175

DATA: 16/10/2007



UFFICIO TECNICO
Via Verdi,16-20095
CUSANO MILANINO
TEL. 02/6192097

DESCRIZIONE: **UD CT 6,3 x L**

DESCRIZIONE DETTAGLIATA :

Vite autoformante Lanthane.