

Scheda tecnica UD CS GREZZA 6.3x25



Tabella Tecnica Autoformante INOX per ferro

<p>Trazione  15000 N</p>		<p>Spessore [mm] Preforo [mm]</p>	<p>Sfilamento</p> 
<p>Taglio  12000 N</p>			<p>3 5 4 5.35 5 5.60 6 5.80</p>
<p>N=Newton 1N=kgf 0.1019716</p>			

MATERIALE: Acciaio INOX AISI 304

TRATTAMENTO: Brillantatura

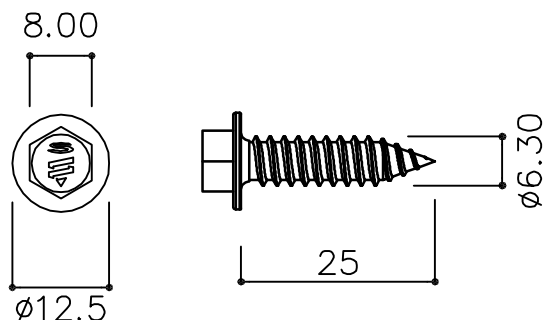
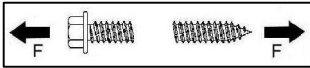
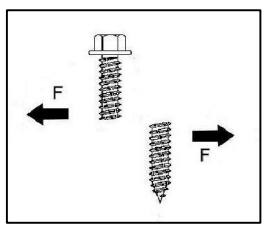
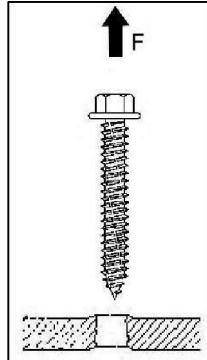
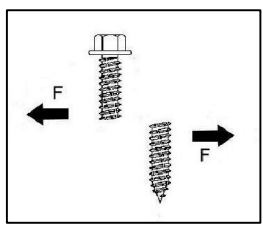
RIVESTIMENTO:

SCALA: 1:1

FIRMA: Uff. Tecnico

DATA: 29/05/2015



UFFICIO TECNICO
Via dell'Industria,12
20032 Cormano - Mi
TEL. 02/6192097

DESCRIZIONE: UD CS GREZZA 6,3 X 25

DESCRIZIONE DETTAGLIATA

Vite autoformante INOX per ferro