

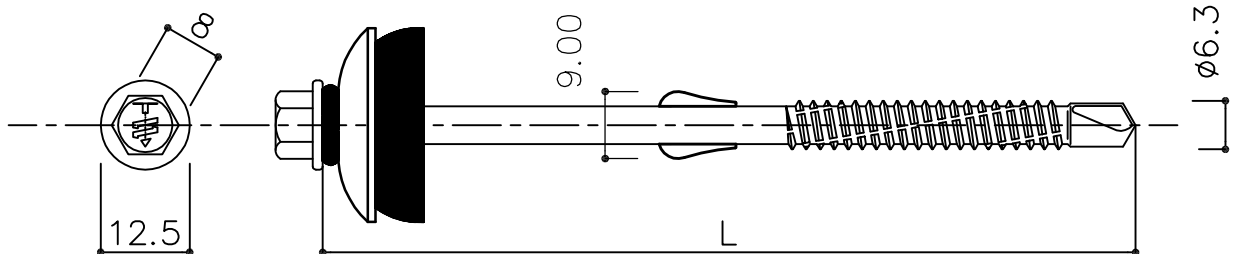

# Scheda tecnica UCF6 KKK 6.3xL



## Tabella Tecnica Autoperforante per Fibrocemento su ferro

<b>Trazione</b>  19.000 N	 Spessore [mm]	Sfilamento ferro 
<b>Taglio</b>  12.000 N		
N=Newton    1N=Kg 0.1019716	3 4 5 6	6.580 N 9.080 N 12.600 N 15.500 N

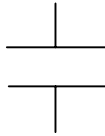
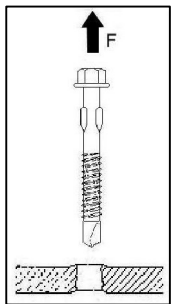
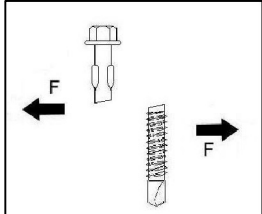
**MATERIALE:** Acciaio al carbonio C21

**TRATTAMENTO:** Carbonitrurazione

**RIVESTIMENTO:** Lanthane 175

**SCALA:** 1:1

**FIRMA:** Uff. Tecnico

**DATA:** 27/09/2011



UFFICIO TECNICO  
Via dell'Industria, 12  
20032 - Cormano  
TEL. 02/6192097

**DESCRIZIONE:** UCF6 KKK 6,3 X L

**DESCRIZIONE DETTAGLIATA:**

Vite autoperforante Lanthane con guarnizione.