

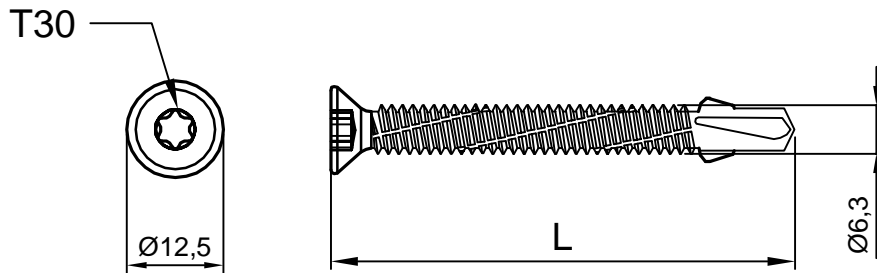

# Scheda tecnica UC6 6.3xL



## Tabella Tecnica Autoperforante con alette

<b>Trazione</b> 	<b>Spessore mm</b> 	<b>Sfilamento ferro</b> 
<b>Taglio</b> 	3 4 5 6	19000 N  6500 N 9000 N 12600 N 15500 N

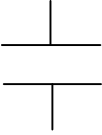
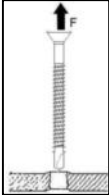
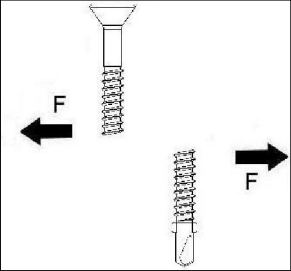
N=Newton      1N=kgf 0.1019716

**MATERIALE:** Acciaio Carbonio C18  
**TRATTAMENTO:** Carbonitrurazione  
**RIVESTIMENTO:** Lubrificante di Zincatura

**SCALA:** 1:1  
**FIRMA:** Uff. Tecnico  
**DATA:** 05/06/2015



**DESCRIZIONE:** UC6 6.3 x L

UFFICIO TECNICO  
 Via dell'Industria,12  
 20032 - Cormano (MI)  
 TEL. 02/6192097

**DESCRIZIONE DETTAGLIATA:**

**Vite autoperforante zincata con alette.**